

CP-111 DEMOLITION TOOLS

ROCK DRILL 597

SECOND EDITION

JUNE 1983

Supersedes First Edition June, 1975

Instruction and Parts Book for

DEMOLITION TOOL

CP-111, Models "A" & "K"

CP-111-S, Models "A" & "K"

**PROTECT YOUR INVESTMENT
IN THE WORLD'S FINEST AIR TOOLS
USE GENUINE CP REPLACEMENT PARTS**

The purchase of replacement parts for your CP tools deserves the same good judgment that resulted in the purchase of the tools themselves. Each genuine CP part is made from carefully selected and inspected material, subjected to sophisticated machinery and finishing

processes and heat-treated to produce just the right combination of hardness, ductility and impact resistance for its intended use. Each part is identical to, and made concurrently with, parts used in production tools. The use of parts other than genuine CP replacement parts can lead to substandard performance, early failure, possible damage of other parts and, in some instances, unsafe conditions.

ROCK DRILL 597



**Chicago
Pneumatic**

Chicago Pneumatic Tool Company ★ Rock Hill, SC29730

R 278144

GENERAL INSTRUCTIONS

CP Demolition Tools are built to stand up under severe service, and if the following instructions are observed, maximum performance will be obtained.

INSTRUCTIONS for SAFE OPERATION

1. The operator should keep his hands off the trigger or throttle until he is ready to start the tool.
2. The operator should keep both feet on the ground and maintain balance at all times.
3. The operator should ensure that his face is never close to the tool.
4. Always wear approved safety footwear and eye and ear protective devices to avoid personal injury.
5. The tool or accessory should never be rested on the operator's toes.
6. The tool should never be started when laying on the ground.
7. The operator should never use his body to control the tool while it is in operation.
8. Both hands of the operator should be kept on the handle of the tool while it is in operation.
9. The lubricant should comply with Chicago Pneumatic's recommendation.
10. When the tool is not in use, remove the accessory unless it is retained in a positive manner.
11. A percussive tool shall not be operated unless the chisel, rivet set or other is in position in the tool and is in contact with the workpiece. Tools shall not be used in such a manner that ejection of an accessory might endanger adjacent personnel.

Lubrication

The modern demolition tool has a number of close-fitting precision made parts, therefore it is highly important that the tool receive reasonable care, adequate lubrication at all times, and regular inspections. As it comes from the factory, the inside of the tool is coated with heavy oil to protect the working parts from rust. After unpacking, pour a small amount of kerosene in the air connections and chuck end and run tool on partial throttle, following immediately with a liberal amount of light oil.

Keep the oil chamber in the handle well filled with a good grade of light oil such as CP's Air-olene Tool Oil, Exxon Arox EP65, Mobil Almo #3, Texaco Regal Oil PE, Shell Tonna R41, or Chevron's Vistac Oil 19x. If oil of the correct viscosity is being used, the oil chamber will require refilling at least every two hours of operation. Use S.A.E. # 10 when the tool is new or in cold weather but never use heavier than S.A.E. # 30 even in warm weather.

If oil does not feed adequately, thoroughly clean the oil chamber and ports, particularly the small "Oil Leak Flat"

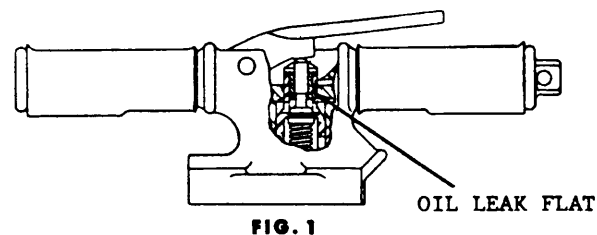

shown in Figure 1. Air line oiler, which should be used in conjunction with the integral oiler, can be supplied in capacities up to one pint. The rate of feed needs to be adjusted according to the oil characteristics and the air consumption of the tool. The closed handle CP-111, does not have an oiler, an air line oiler must be used. The importance of adequate and continuous lubrication cannot be overemphasized. A few minutes operation without oil, particularly when new, may severely damage the valve parts, cylinder, piston, etc., thereby reducing the efficiency of the tool for its remaining life. Two external indications of adequate lubrication are (a) moderate amount of atomized oil in main exhaust air (b) presence of slight amount of oil on steel shanks.

Be sure steel shanks are of correct size and length, and not chipped or rounded on striking end. Shanks of improper length reduces the effectiveness of the blow. End of shank must be softer than face of piston.

Air Supply

CP Demolition Tools are designed to operate most efficiently on air pressures ranging from 80 to 90 lbs. (5.5-6.2 bar). High air pressure causes roughness and excessive breakage. Low air pressure reduces efficiency. Air hose of 3/4" ID or larger should be used. The use of our filter and lubricator is highly recommended.

Operating Cautions

The following fundamentals of good operation should be observed:

1. Before connecting air hose to tool, the air receiver and air hose should be "blown" to remove any accumulation of moisture and dirt. See that inlet is free from dirt and exhaust ports clear.
2. Pour a small amount of oil in the air inlet before connecting hose.
3. Tool should be held down to its work. Do not operate tool on full throttle while off the work.
4. Do not use over dull steels, or steels which are chipped and broken on their hex end.
5. Do not run tool with loose backhead bolts. This not only causes bolt breakage but destroys accurately ground faces.
6. Do not lay tool down in dust or dirt without first plugging all openings with rags.

Maintenance

Dismantling and inspection at regular intervals (at least once a week if tool is being used regularly) will greatly assist in maintaining efficiency and avoiding high upkeep costs. It is false economy to continue to use worn out parts.

1. Faces must be kept clean, smooth and tight.
2. Internal parts must be kept free of rust, grit or other foreign matter.
3. Valve parts should be cleaned, inspected and checked to make sure valve works freely.

Fronthead

Unduly worn frontheads will permit steels to be struck while in a misaligned position by the piston thus damaging striking face of piston.

Assembly Cautions

Reasonable care must be taken during assembly and disassembly of CP111 Demolition Tools to avoid burring, scoring or distortion of closely fitted precision built parts.

In addition observe the following specific cautions.

1. Check all metal to metal surfaces for nicks and burrs before and during assembly.
2. Before re-assembly lubricate all 'O' Rings and coat all moving parts of tool with recommended lubricant.
3. During assembly use care to keep dirt out of tool, particularly between mating surfaces.
4. To avoid bolt failure pull up backhead bolts or side rods evenly by alternating from one to the other so as to distribute the load evenly. Torque nuts to 115 - 125 ft. lbs.
5. Particularly when new, nuts and other outside parts should be gone over frequently until all parts have taken their final "set".
6. When air inlet bushings are provided, see that bushing is screwed in 90-110 ft. lbs. to prevent thread wear.
7. Fill oil chamber and tighten oil plug to 50-60 ft. lbs. torque, pour about 1/2 oz, recommended oil into the air inlet and operate tool on reduced throttle for 10-15 seconds.
8. If it is necessary to operate tool on the floor, do so at reduced throttle to avoid damage to piston and fronthead.

Hand ream R070109 to 0.3105" / 0.311" after assembly.

ACCESSORIES

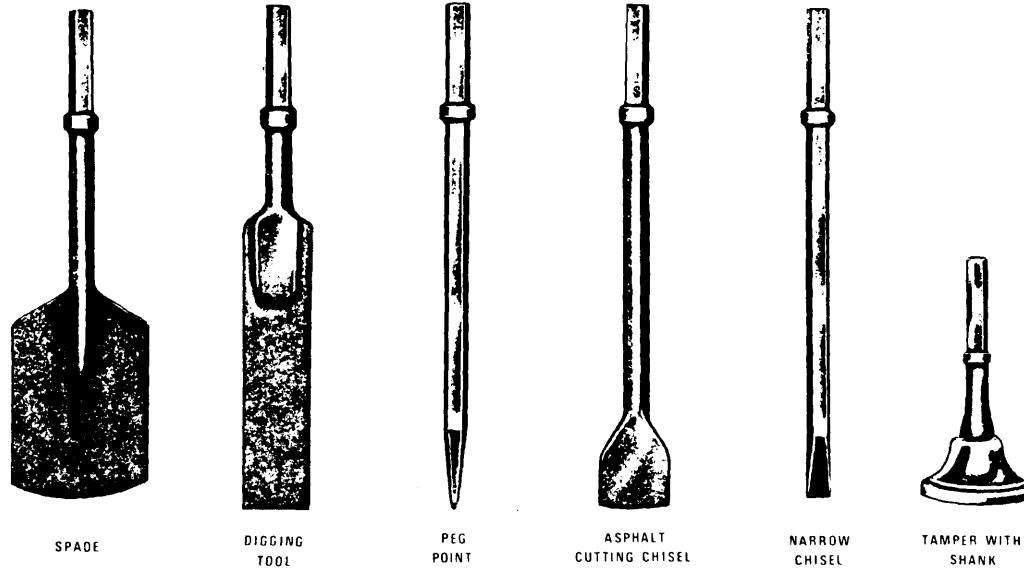

DESCRIPTION	TYPE SHANK
	1" HEX. X 4 1/4"
14" Peg Point	R-070115
18" Peg Point	R-085502
24" Peg Point	R-085503
36" Peg Point	R-085522
14" Narrow Chisel - 1 1/8" Wide	R-070131
18" Narrow Chisel - 1 1/8" Wide	R-085501
11" Asphalt Chisel - 5" Blade	R-098070
14" Asphalt Chisel - 3" Blade	R-070118
Spade - 5 1/2" Wide	R-070116
Digging Tool - 3" x 10" Blade	R-070119
Tamper (Less Shank) 6" Square	R-053282
Shank (Less Tamper)	R-053283

Also Available : Peg Points and Chisels, Heavy Duty Type, having round steel below collar instead of hexagon, as well as Special Peg Points and Narrow Chisels longer than listed above. Consult your CHICAGO PNEUMATIC representative for further information.

When ordering spare parts, give Name, Speed or Size, Model and Serial Number of the tool and Part Number and Description of each part desired.

CP - 111/CP -111-S DEMOLITION TOOL Models "A" & "K"

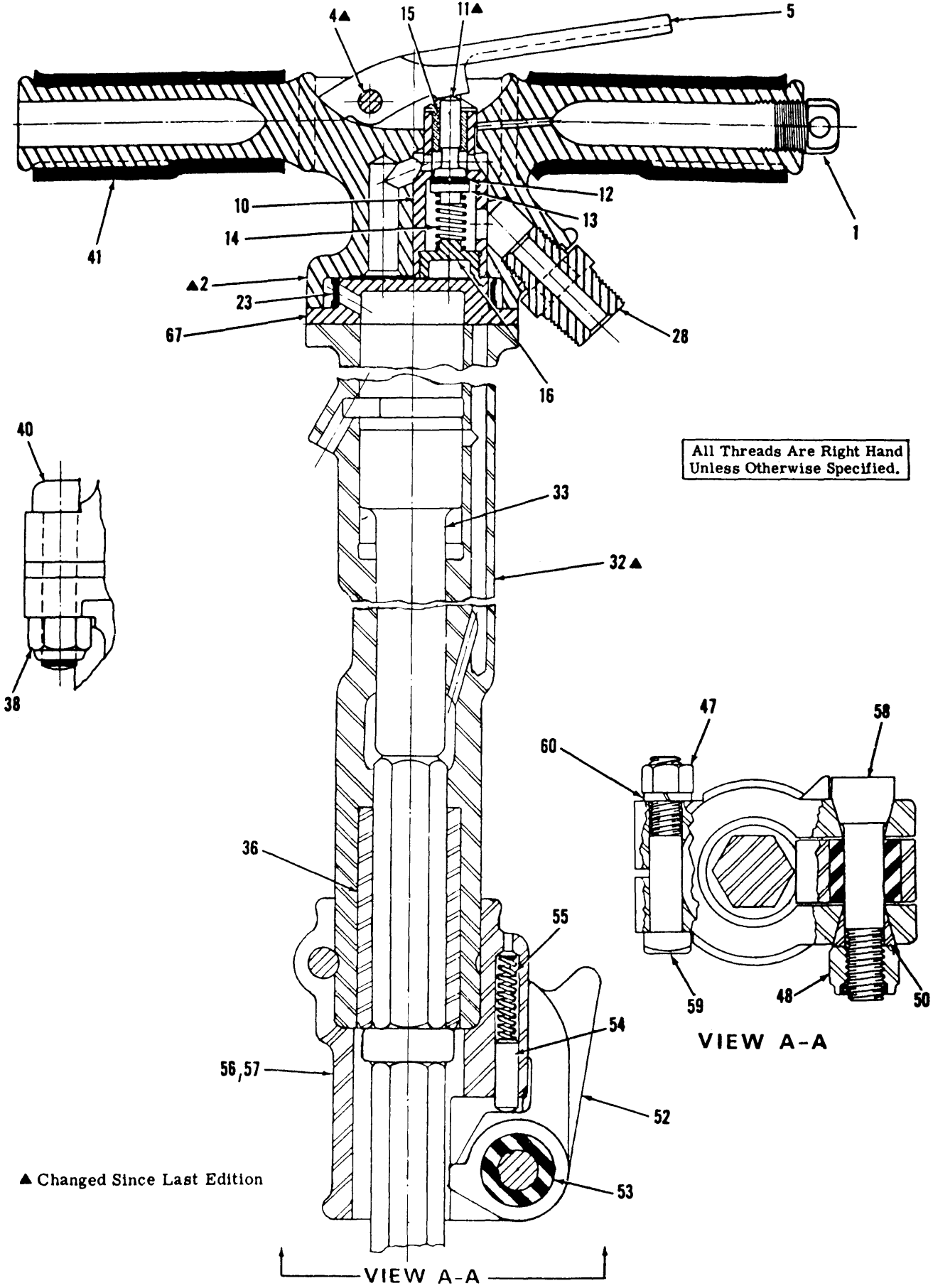

CP - 111/CP -111-S DEMOLITION TOOL Models "A" & "K"

* USED ON CP-111-S DEMO ONLY

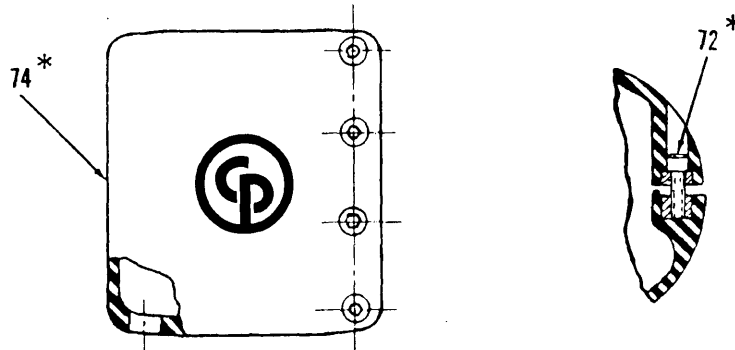

▲ Changd Since Last Edition

Index No.	CP Part No.	Description	No. Req'd
1	R-000560	Plug-Oil	1
2▲	R-070105	Backhead (Double Grip) (Incl : Index NO's 10 & 15)	1
4▲	R-133433	Pin - Trigger	1
5	R-070110	Lever - Throttle Valve	1
10	R-070106	Bushing - Throttle Valve	1
11▲	R-045370	Valve - Throttle (Incl : Index No's 12 & 13)	1
12	R-045375	Seal - Valve	1
13	R-045374	Retainer - Seal	1
14	R-001836	Spring - Throttle Valve	1
15	R-070109	Bushing - Throttle Valve Stem	1
16	R-070108	Plug - Throttle Valve Bushing	1
23	R-070103	Valve	1
28	R-075227	Nipple - Air Inlet	1
32▲	R-137060	Cylinder (Incl : Index No. 36)	1
33	R-070102	Piston	1
36	R-070112	Bushing - Chuck (1" Hex x 4 1/4")	1
38	P-006099	Nut - Backhead Bolt (9/16" - 18)	4
40	R-070111	Bolt - Backhead (9/16" - 18)	4
41	R-005716	Handle - Rubber	2
47	R-000555	Nut - Head Latch (1/2" - 13)	1
48	P-081091	Nut - Latch Retainer (5/8" - 18)	1
50	R-092499	Bushing - Latch Retainer Bolt	1
52	R-092493	Retainer - Latch	1
53	R-048540	Bushing - Latch Retainer	1
54	R-092497	Plunger - Latch Retainer	1
55	R-086982	Spring - Latch Retainer Plunger	1
56	R-092500	Latch Type Retainer (Incl : Index No's 47, 48, 50, 52, 53, 54, 55, 57, 58, 59 & 60)	1
57	R-092492	Head - Latch Retainer	1
58	R-092498	Bolt - Latch Retainer (5/8" - 18 x 3 1/2")	1
59	P-002123	Bolt - Head Latch (1/2" - 13 x 2 3/4")	1
60	C-036717	Lockwasher - Head Latch	1
67	R-070104	Block - Valve	1
72	P-072446	Screw - Cap (1/4" - 28 x 5/8")	4
74	F-814133	Muffler - Complete (Incl : Index No. 72)	1

When ordering spare parts, give Name, Speed or Size, Model and Serial Number of the tool and Part Number and Description of each part desired.

CP - 111/CP -111-S DEMOLITION TOOL Models "A" & "K"

R - 278139 BACKHEAD COMPLETE - OUTSIDE TRIGGER

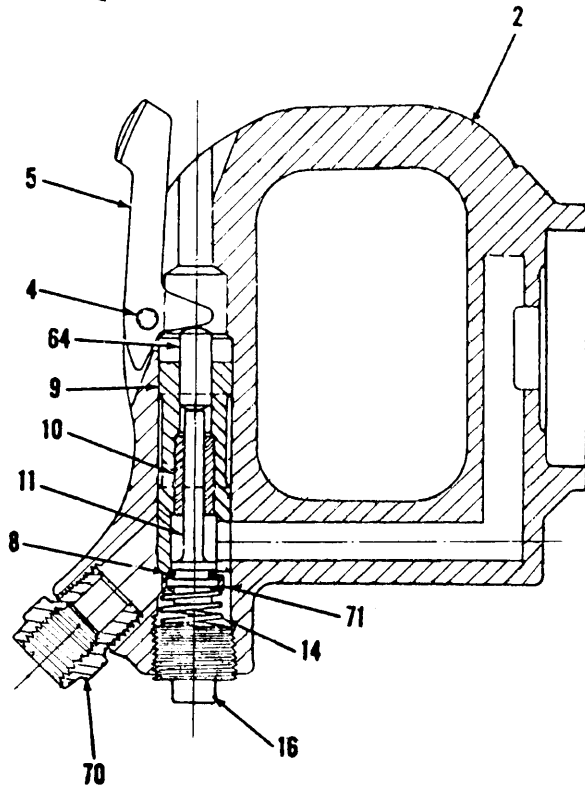

All Threads Are Right Hand
Unless Otherwise Specified.

Index No.	CP Part No.	Description	No. Req'd
2	R-070114	Backhead (Incl : Index No's 9 & 10)	1
4	A-043627	Pin - Lever	1
5	P-003070	Lever - throttle Valve	1
8	CA-088867	'O' Ring (-110)	1
9	P-005154	Bushing - Throttle Valve	1
10	P-005157	Bushing - Push Pin (Ream. 2498 - 2502 After Assy)	1
11	P-092090	Valve - Throttle	1
14	P-006170	Spring - Throttle	1
16	P-001884	Plug - Throttle Valve	1
64	P-005156	Pin - Plush	1
70	P-001983	Bushing - Air Inlet	1
71	P-092091	Retainer - 'O' Ring	1

R-278141 BACKHEAD COMPLETE - INSIDE TRIGGER

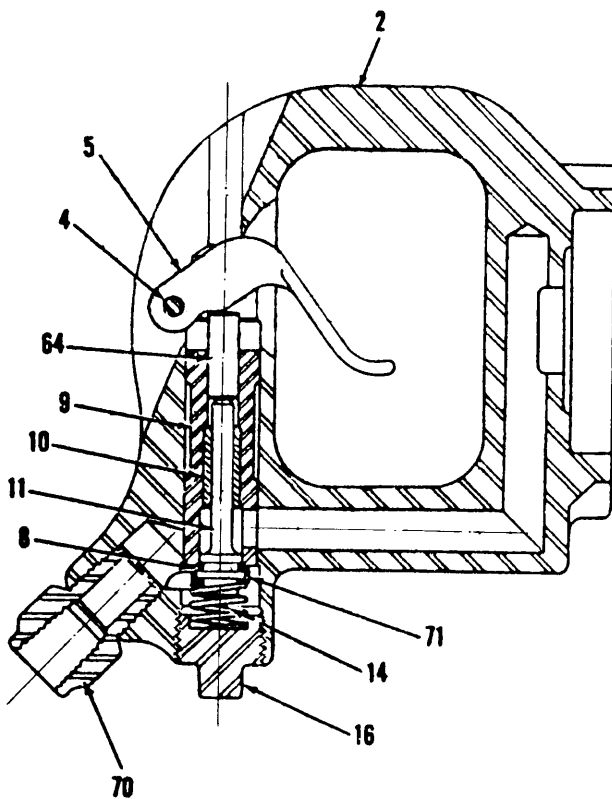

All Threads Are Right Hand
Unless Otherwise Specified.

Index No.	CP Part No.	Description	No. Req'd
2	R-093104	Backhead	1
4	A-043627	Pin - Lever	1
5	R-093103	Lever - Throttle Valve	1
8	CA-088867	'O' Ring (-110)	1
9	P-005154	Bushing - Throttle Valve	1
10	P-005157	Bushing - Push Pin	1
11	P-092090	Valve - Throttle	1
14	P-006170	Spring - Throttle	1
16	P-001884	Plug - Throttle Valve	1
64	P-005156	Pin - Push	1
70	P-001983	Bushing - Air Inlet	1
71	P-092091	Retainer - 'O' Ring	1

CP - 111/CP -111-S DEMOLITION TOOL Models

BACKHEAD AND EXTENSION HANDLE COMPLETE
R-278134 (INCLUDES INDEX NO'S 1 thru 14, 28 and 51 thru 66)

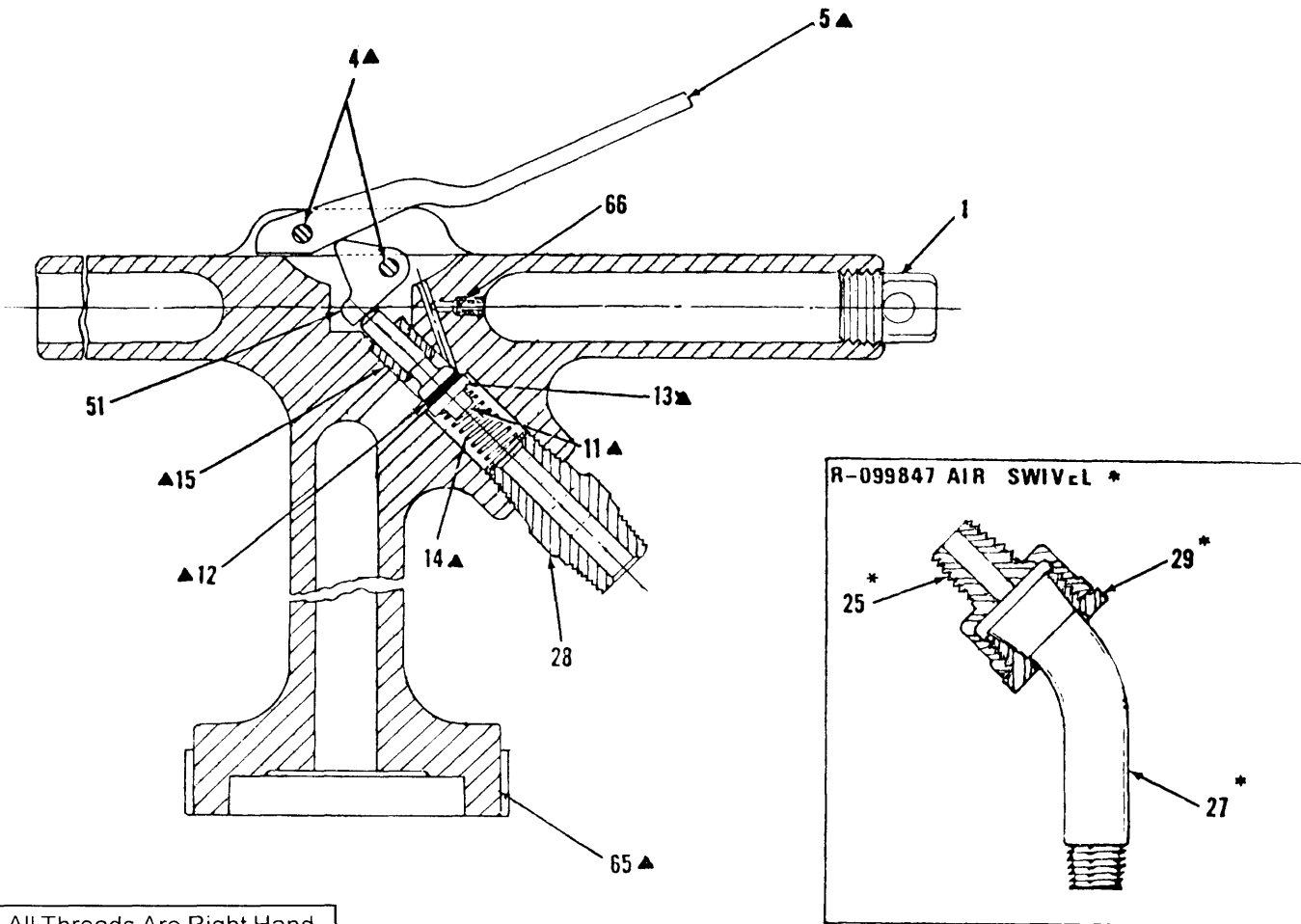

All Threads Are Right Hand
Unless Otherwise Specified.

* SPARE PARTS ONLY

▲ Changd Since Last Edition

Index No.	CP Part No.	Description	No. Req'd
1	R-000560	Plug - Oil	1
4 ▲	P-001921	Pin - Lever	2
5 ▲	P-001903	Lever - Throttle Valve	1
11 ▲	R-045370	Valve - Throttle (Incl : Index No's 12 & 13)	1
12 ▲	R-045375	Seal - Valve	1
13 ▲	R-045374	Retainer - Seal	1
14 ▲	P-001836	Spring - Throttle Valve	1
15 ▲	R-070109	Bushing - Throttle Valve	1
25 *	R-099765	Adapter - Swivel	1
27 *	R-099766	Swivel - Air	1
28	R-075227	Nipple - Air Inlet	1
29 *	R-075599	Nut - Air Inlet	1
51	R-085220	Cam - Lever	1
65 ▲	R-085219	Handle - Extension (Incl : Index No's 15 & 16)	1
66	R-004976	Plug - Oil Regulating	1

When ordering spare parts, give Name, Speed or Size, Model and Serial Number of the tool and Part Number and Description of each part desired.