

CP-1210 & CP-1210S DEMOLITION TOOLS

PNEUMATIC M & C 670

FIRST EDITION

FEBRUARY 1986

Supersedes Second Edition January, 1983

WARNING - TO AVOID INJURY SEE
CAUTIONS INSIDE

Instruction and Parts Book for

DEMOLITION TOOL

CP-1210 & CP-1210S

Model 'A' & 'U'

**PROTECT YOUR INVESTMENT
IN THE WORLD'S FINEST AIR TOOLS
USE GENUINE CP REPLACEMENT PARTS**

The purchase of replacement parts for your CP tools deserves the same good judgment that resulted in the purchase of the tools themselves. Each genuine CP part is made from carefully selected and inspected material, subjected to sophisticated machinery and finishing

processes and heat-treated to produce just the right combination of hardness, ductility and impact resistance for its intended use. Each part is identical to, and made concurrently with, parts used in production tools. The use of parts other than genuine CP replacement parts can lead to substandard performance, early failure, possible damage of other parts and, in some instances, unsafe conditions.

M & C 670



**Chicago
Pneumatic**

Chicago Pneumatic Tool Company ★ Rock Hill, SC29730

C-133364

GENERAL INSTRUCTIONS

Preparing for Operation

CP-1210 and CP-1210S Demolition Tools are built to stand up under severe service, and, if the following instructions are observed, maximum performance will be obtained with a minimum of delay and maintenance.

Safety Cautions

Normal operation of a demolition tool can cause flying particles that can cause eye injury. Wear safety goggles.

To prevent gradual loss of hearing due to exposure to high sound level, wear ear protection.

A demolition tool is heavy enough to cause foot injury if accidentally dropped or placed on an operators foot. Metatarsal safety shoes are recommended protection.

Always hold cutting tool down firmly on work before depressing throttle lever.

Always make sure cutting tool is securely latched in demolition tool before depressing throttle lever.

To avoid injury from ejected steel, make sure the latch mechanism is in good working order. Replace worn or broken parts to maintain proper steel retention.

Always check for damaged or loose hoses and fittings before operation. Whipping hoses can cause serious injury.

Prolonged use of vibrating tools by certain users may be harmful to hands and arms.

Air supply

To enable the tool to function satisfactorily, it is essential that a constant 80-90 PSIG (5.6-6.2 bar) of clean, dry air is supplied to the air inlet. Air piping should be a minimum of 3/4" hose size or larger used with couplings of a minimum 9/16" I.D. The installation of an air line separator and filter to purify and dry the air supply and pressure regulator to eliminate any pressure fluctuations are recommended. The control units should be located as near to the tool as operation will allow.

Lubrication

The modern demolition tool has a number of close fitting parts and it is highly important that the tool receive reasonable care and regular inspections and adequate lubrication at all times.

As it comes from the factory, the inside of the tool is coated with heavy oil to protect the working parts from rust. After unpacking pour a small amount of kerosene in both the air connection and the chuck end and operate the tool on partial throttle. Then disconnect tool and pour a generous amount of light oil into air connection.

Keep the oil chamber in the handle well filled with a grade of light oil recommended by reputable oil companies for this type of tool. See recommended specifications for lubricant.

Air line lubricators, to be used in conjunction with the integral oiler, can be supplied in capacities up to one pint. The rate of feed needs to be adjusted according to the oil characteristics and the air consumption of the tool. The importance of adequate and continuous lubrication cannot be overemphasized. A few

minutes operation without oil particularly when the tool is new, may severely damage the valve parts, cylinder and piston which will reduce the efficiency of the tool for its remaining life.

Two external indications of adequate lubrication are the appearance of a slight amount of oil on the steel shanks and the appearance of enough atomized oil in the main exhaust air to be visible on the bare hand.

Recommended Lubricants

Manufacturer	Below 40°F	40°F to 80°F	Above 80°F
CP	Airolene Tool Oil		
Esso	Arox EP45	Arox EP65	
Mobil Oil	Valocite No. 10	Almo No. 3	Almo No. 5
Texaco	Regal Oil B (R & O)	Regal Oil PE (R & O)	Regal Oil F (R & O)
Daiton	Silkolene 773	Silkolene 548/T	Silkolene 881
Shell	Tonna R27	Tonna R41	Tonna R72
Burmah Castrol	Magns SPX	Castrol RD Oil Light	Castrol RD Oil 3
BP Power Petroleum	RD60 HP 10-C	RD 150 HP20-C	RD 220 HP60-C
Duckham	Zero Flo 5	Garnet 6	Garnst 7
Sternol	Merlin 54	Merlin 71	Merlin 87
Petrofina	Purifoc 32	Purifoc 46	Purifoc 53
Chevron	Vistac Oil 9X	Vistac Oil 19X	Vistac Oil 18X
Caltex	Caltex XL	Caltex XM	Caltex XH

Operating Instructions

The fundamentals of good operation listed in this section should be observed in order to achieve the maximum performance of the tool.

1. Daily before using, blow out the air receiver and air hose to remove accumulated dirt and moisture from the air line. Inspect tool to make sure that air inlet and exhaust ports are clear and free from dirt.
2. Before connecting air hose, pour a small amount of oil into the air inlet and fill the oil chamber in the handle.
3. Always hold tool down to the work. Operation of the tool without a steel or without holding it against the work will put excessive strain on fronthead. See "Assembly Cautions" No. 7.
4. Be sure steels are not over-dull and that steels and shanks are of the correct size and length. Inspect steels and do not use those chipped or rounded on the striking end. Shanks of improper length reduce the effectiveness of the blow. Striking end of shank must be softer than the face of the anvil block.
5. Keep backhead bolts tight. The accurately ground faces of valve, cylinder and backhead will be destroyed and bolt breakage will result from operation with loose backhead bolts.
6. Particularly when new external parts should be inspected and threaded connections frequently retightened until all parts have taken their final set.
7. Do not lay tool down in dust or dirt without first plugging all openings with rags.
8. CP-1210 Demolition Tools are designed to operate most efficiently at 80 to 90 PSIG (5.6 to 6.2 bar) air pressure. Roughness and excessive breakages will result from operation at high pressures while low pressure will cause slowness and inefficient operation.

9. Always wear approved eye protection and safety type shoes to avoid personal injury.

Maintenance

Dismantle and inspect tool at regular intervals (at least once a week if tool is being used regularly), to maintain efficiency and avoid high upkeep costs. It is false economy to continue to use worn out parts.

1. Be sure mating faces are clean and smooth and that backhead bolts are tight.
2. Thoroughly clean and inspect internal parts and make sure they are free from rust, grit and foreign matter.
3. Thoroughly clean and inspect valve parts. Be sure valve moves freely.
4. Make sure striking faces of anvil block is square. If block is cupped grind off high edges but to not touch the polished face where the anvil block strikes the steel shank.

Assembly Cautions

Reasonable care must be taken during assembly and disassembly of CP-1210 Demolition Tool to avoid burring, scoring or distortion of closely fitting, precision-built parts. In addition, observe the following specific cautions :

1. Check all metal to metal surfaces for nicks and burrs before and during assembly.
2. Before re-assembly lubricate all "O" rings and coat all moving parts of tool with recommended lubricants.
3. During assembly, use care to keep dirt off the tool, particularly between mating surfaces.

4. Fronthead bolt nuts (21) should be drawn up so the springs (19) are evenly compressed from 1/8" to 3/16" but not compressed so tightly that coils touch. This will give the springs an assembled length of 43.7 mm (1 23/32") to 42.1 mm (1 21/32").

5. Install air inlet swivel (30) and tighten nut (24) to 108-136 Nm (80-100 ft. lbs) torque.

6. When assembling is complete fill oil chamber and tighten oil plug (39) 54-61 Nm (40-45 ft. lbs.) torque. Pour about 1/2 oz. oil as recommended by reputable oil reduced throttle for 10- 15 seconds.

7. If it is necessary to operate the tool on the floor, do so at reduced throttle to avoid damage to piston, anvil block and fronthead.

8. Install outer pin (22) in tool from chamfer side of hole and with the three wraps toward the front. The material overlap is at 45° as shown below.

Then install inner pin (42) within the outer pin. The three wraps should also be facing toward the front with the material overlap at 45°

See illustration shown below.

9. On CP-1210S Models, tighten screws (41) on muffler (40) 20-25 ft. lbs. torque. Do not omit any screws.

10. When assembling valve case, insert valve (4) in case (2) and, using an arbor press, press valve case cover (3) into case. If pipe plug (6) has been removed, re-tighten to 20-25 ft. lbs. torque. Install "O" ring (5) on case and slide assembled case into backhead (13) on top of spacer (7).

11. Before assembling backhead (13) to cylinder (31) check that seal (29) protudes approximately 1/16" from face of cylinder.

12. Always wear approved eye protection and safety type shoes to avoid personal injury.

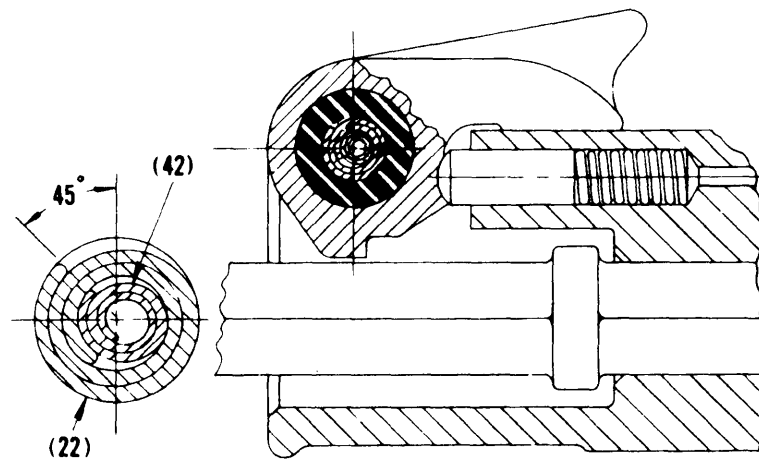

CP - 1210 & CP 1210S DEMOLITION TOOLS

Index No.	CP Part No.	Description	No. Req'd
1 ▲	F-815071	Valve Case Assembly (Incl : Index No's 2 thru 6)	1
2	R-110206	Case-Valve	1
3	R-110207	Cover-Valve Case	1
4	R-110208	Valve	1
5	R-110210	"O" Ring (-139)	2
6	C-054987	Plug-Pipe (1/8")	1
7	R-110209	Spacer-Valve Case	1
8	R-092493	Retainer-Latch	1
9	R-048540	Bushing-Latch	1
10	F-815274*	Backhead Complete (Incl : Index No's 11, 12 & 13)	1
11	F-814725	Lever-Throttle	1
12	R-133433	Pin-Roll	1
13	F-814725	Backhead (Incl : Index No. 39 & 44)	1
14	F-815719	Fronthead (For UK)	1
15	F-815478	Fronthead (For USA)	1
16	R-041073	Lock-Nut	2
17	R-086982	Spring-Plunger	1
18	R-092497	Plunger-Latch	1
19	R-093698	Spring-Fronthead	2
20	R-110217	Bolt-Fronthead	2
21	R-110218	Nut-Fronthead Bolt	2
22	R-133434	Pin-Retainer Latch (Outer)	2
23	R-005717	Spring-Throttle Valve	1
24	R-075599	Nut-Air Inlet	1
25	R-085427	Block-Anvil	1
26	R-110203	Bushing-Anvil Block	1
27	R-110212	Piston	1
28	R-110214	Bolt-Backhead	4
29	R-110215	Seal-Cylinder	1
30	F-814720	Swivel-Air Inlet	1
31	F-814724	Cylinder	1
32	C-065384	Lockwasher	4
33	R-114525	Nut-Backhead	4
34	R-056605	"O" Ring (-124)	1
35	C-106884	"O" Ring (-019)	1
36	R-092894	Valve-Throttle (Incl : Index No. 37 & 38)	1
37	R-098368	Seal-Throttle Valve	1
38	R-098369	Ring-Valve Seal Retaining	1
39	R-075031	Plug-Oil	1
40	F-814928	Muffler Complete (Incl. Ind. No.41)for USA	1
40	R-146351	Muffler Complete (For Europe) (Incl : Index No. 41)	1
41	R-117415	Screw-Allen Cap	3
42 ▲	R-139735	Pin-Retainer Latch (Inner)	1
43 ▲	F-816345	Grip	2
44 ▲	C-036901	Plug-Oil Regulating (Not Shown)	1

* It is recommended to order Handle Grips
Part number F-816345 when ordering Backhead
two (2) Grips required for each Backhead ordered.

▲ Changed Since Last Edition

When ordering spare parts, give Name, Speed or Size, Model and Serial Number of the tool and Part Number and Description of each part desired.

DEMOLITION TOOL ACCESSORIES

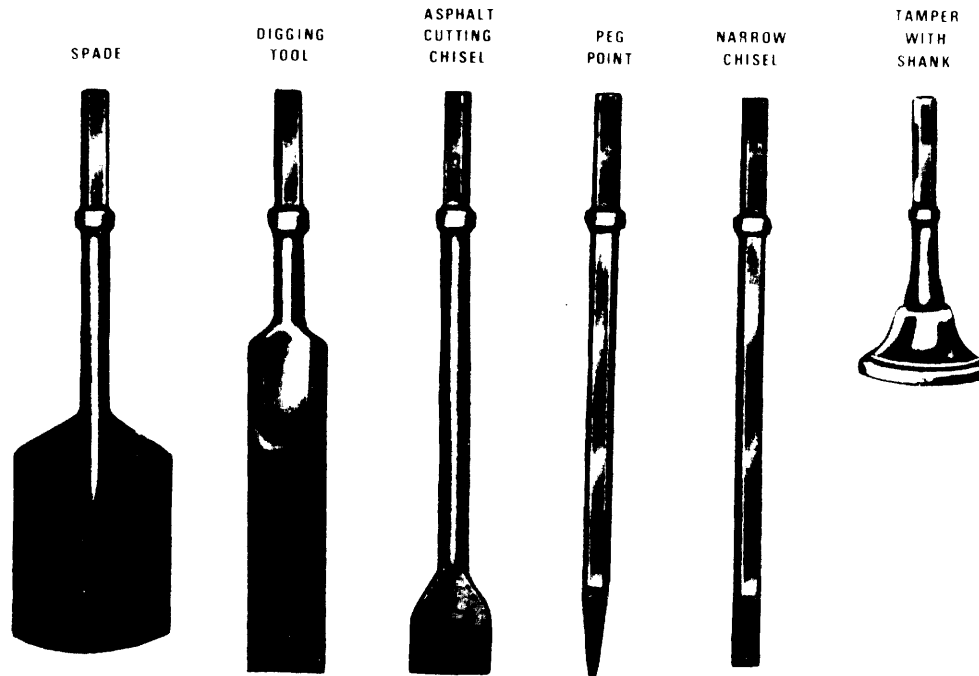

Description	TYPE SHANK
	1" Hex. 4 1/4"
14" Peg Point	R-070115
18" Peg Point	R-085502
24" Peg Point	R-085503
36" Peg Point	R-085522
14" Narrow Chisel - 1 1/8" Wide	R-070131
18" Narrow Chisel - 1 1/8" Wide	R-085501
11" Asphalt Chisel - 5" Blade	R-098070
14" Asphalt Chisel - 3" Blade	R-070118
Spade - 5 1/2" Wide	R-070116
Digging Tool - 3" x 10" Blade	R-070119
Tamper (Less Shank)	R-075229
Shank (Less Tamper)	R-075228

Also Available : Peg Points and Chisels, consult your Chicago Pneumatic representative for information longer than listed above.

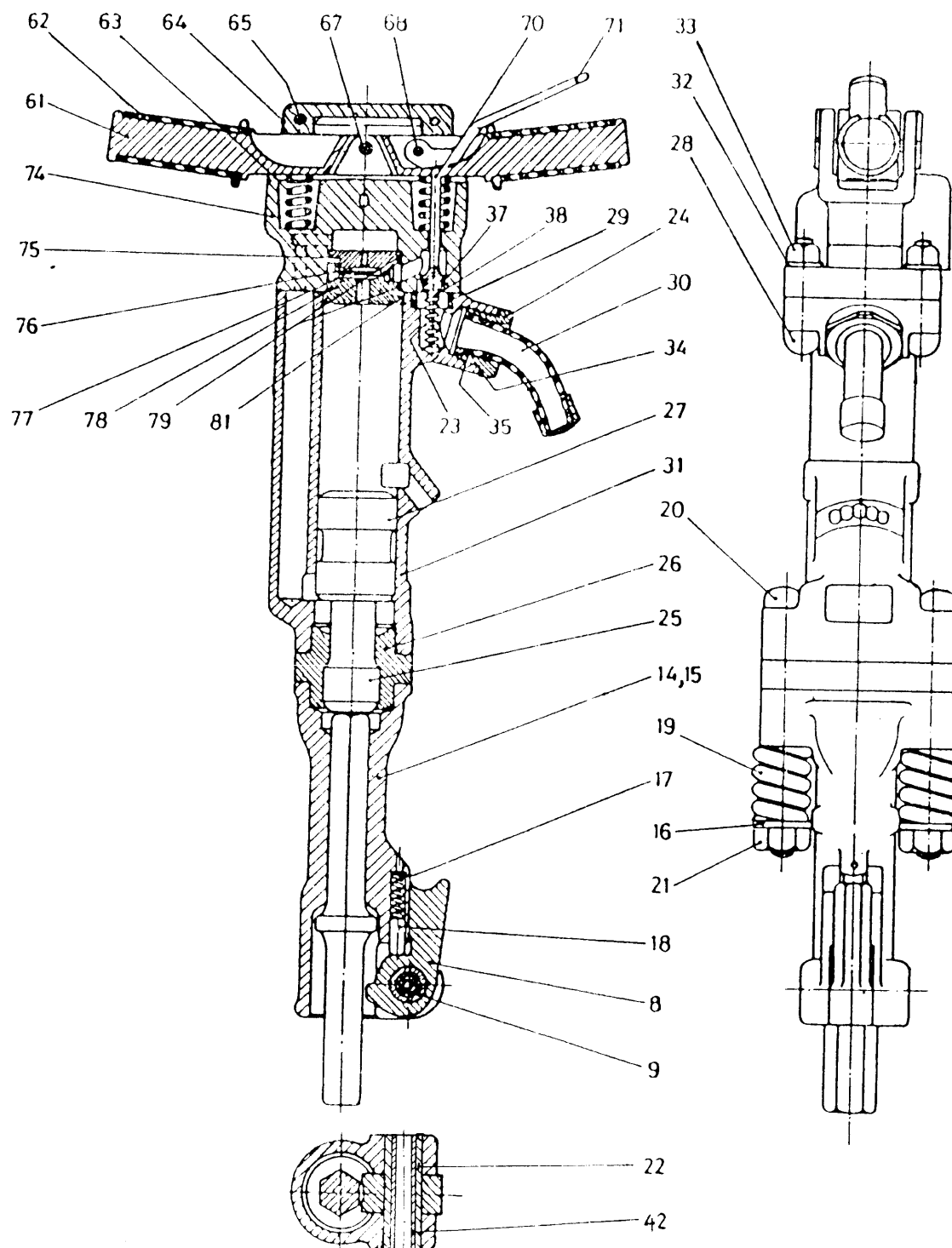

**CP - 1210 & CP 1210 S DEMOLITION TOOL WITH FLEX. HANDLE / STRAIGHT HANDLE
PARTS FOR FLEX. HANDLE (V.R.) OR STRAIGHT HANDLE (SHS)**

Index no.	CP Part No.	Description	No. Reqd.
61	R-146266	Handle (Flex.)	2
62	R-145788	Grip (For Flex. Handle)	2
63	R-145863	Spring (For Flex. Handle)	2
▲ 64	R-157669	Cover - Buffer Replaces old R-145860 & R-14586z	1
▲ 65	R-157670	Pin-Stepped Replaces old R-145865, R145867 & R146816	2
67	R-145864	Pin-Spirol	1
68	R-145866	Pin-Lever	1
70	R-145782	Throttle Valve	1
71	R-145781	Lever	1
★ 72	R-145861	Steel Washer (For Flex. Handle)	3
★ 73	C - 36901	Oil Regulating Plug	1
74	R-145783	Backhead	1
75	R-138096	Upper Valve Lid	1
76	R-138095	Valve Case	1
77	R-138094	Valve	1
78	R-145786	Lower Valve Lid	1
79	C 102642	"O" Ring	2
81	C-125868	"O" Ring (- 034)	1
82	R-147755	Gasket (Above Upper Valve Lid)	1
83	R-004975	Oil Plug Sq. hd.	1
-	R-145777	Backhead-Flex. Complete (Incl. Index Nos. 23, 37, 38 & 61 to 83)	1
61	R-147709	Handle (Straight)	1
62	R-005716	Grip (For Straight Handle)	2
★ 72	R-147710	Washer (For Straight Handle)	2

All other parts same as Standard tool,
refer to listing in page 4 & 5.

★ not shown in the drawing,

▲ Changed since Last Edition

Assembly Cautions

1. Disassembly of the Flex. portion of the handle requires taking pins (65) and (67) out. While reassembly, ensure that Springs (63) are in proper place.
2. Valves can be serviced by removing the backhead bolts (28). Replace "O" rings (79 & 81) if damaged. In reassembly tighten bolts evenly to 45-50 ft. lb. torque.

Operating Cautions

Springs (63) are designed to provide vibration isolation to the handles. While breaking concrete, maintain down pressure to keep handle in 'Flex' mode, but never too much down pressure as to cause the handle to 'bottom' on the backhead negating the vibration isolation.

SPARE PARTS SERVICE CHART

THIS SERVICE CHART IS PUBLISHED AS A GUIDE TO EXPECTANT LIFE OF COMPONENT PARTS. THE REPLACEMENT LEVELS ARE BASED ON AVERAGE TOOL USAGE OVER A ONE YEAR PERIOD.

EXAMPLE : For 10 tools in use : 10 high wear items will be required per year, 7 medium wear items etc.

NOTE : Quantities must be increased where tool is subjected to more severe and /or continuous usage.

LEGEND

X - Type of wear, if no other comments apply

L - Easily lost. Carefully reserve during disassembly.

D - Easily damaged during disassembly and assembly.

INDEX NO	CP PART NO	DESCRIPTION	NO. REQ'D	HIGH WEAR 100%	MEDIUM WEAR 70%	LOW WEAR 30%	NON WEAR 10%	SUBJECT TO EXTERNAL DAMAGES
2	R-110206	Case-Valve	1			D		
3	R-110207	Cover-Valve Case	1			D		
4	R-110208	Valve	1		D			
5	R-110210	"O" Ring	2		D			
6	C-054897	Plug-Pipe (1/8")	1			L		
7	R-110209	Spacer	1				X	
8	R-092493	Retainer-Latch	1	X				
9	R-048540	Bushing-Latch	1			X		
11	F-814725	Lever-Throttle	1			X		
12	R-133433	Pin-Throttle Lever	2		L			
13	F-814723	Backhead	1			X		
15	F-815478	Fronthead (For USA)	1		X			
15	F-515719	Fronthead (For UK)	1		X			
16	R-041073	Lock-Nut	2		X			
17	R-086982	Spring-Plunger	1		L			
18	R-092497	Plunger-Latch	1		L			
19	R-093698	Spring-Fronthead	2		X			
20	R-110217	Bolt-Fronthead	2		X			
21	R-110218	Nut-Fronthead Bolt	2		X			
22	R-133434	Pin-Retainer Latch (Outer)	1	X				
23	R-005717	Spring-Throttle Valve	1			L		
24	R-075599	Nut-Air Inlet	1			X		
25	R085427	Block-Anvil	1		X			
26	R-110203	Bushing-Anvil Block	1		X			
27	R-110212	Piston	1		X			
28	R-110214	Bolt-Backhead	4			X		
29	R110215	Seal-Cylinder	1			X		
30	F-814720	Swivel-Air Inlet	1					X
31	F-814724	Cylinder	1		X			
32	C-065384	Washer-Lock	4		L			
33	R-114525	Nut-Backhead	4			L		
34	R-056605	"O" Ring	1		D			
36	R-092894	Valve-Throttle	1		D			
37	R-098368	Seal-Throttle	1		L			
38	R-098369	Ring-Seal Retaining	1			L		
39	R-075031	Plug-Oil	1					L
40	F-814928	Muffler	1					X
40	R-146351	Muffler Complete (For Europe)	1					X
41	R-117415	Screw-Cap	3				X	
▲42	R-139735	Pin-Retainer Latch (Inner)	1	X				
▲43	F-816345	Grip	2		X			
▲44	C-036901	Plug-Oil Regulating	1				L	

▲ Changed Since Last Edition

When ordering spare parts, give Name, Speed or Size, Model and Serial Number of the tool and Part Number and Description of each part desired.