

**CP - 3250 CONCRETE VIBRATOR**

UTICA PNEUMATIC 614

FIRST EDITION  
MARCH, 1995

|   |   |
|---|---|
|  | <b>WARNING</b> - TO REDUCE RISK OF INJURY,<br>READ AND UNDERSTAND THIS INSTRUCTION<br>MANUAL BEFORE OPERATING TOOL. |
|---|---|

*Instruction and Parts Book for*  
**PNEUMATIC CONCRETE  
VIBRATOR**

CP - 3250 Models "A" & "A-0"

UTICA PNEUMATIC 614



**Chicago  
Pneumatic**

Chicago Pneumatic Tool company + Rock Hill, SC29730

R-27815

CP - 3250 CONCRETE VIBRATOR Models "A" & "A-0"

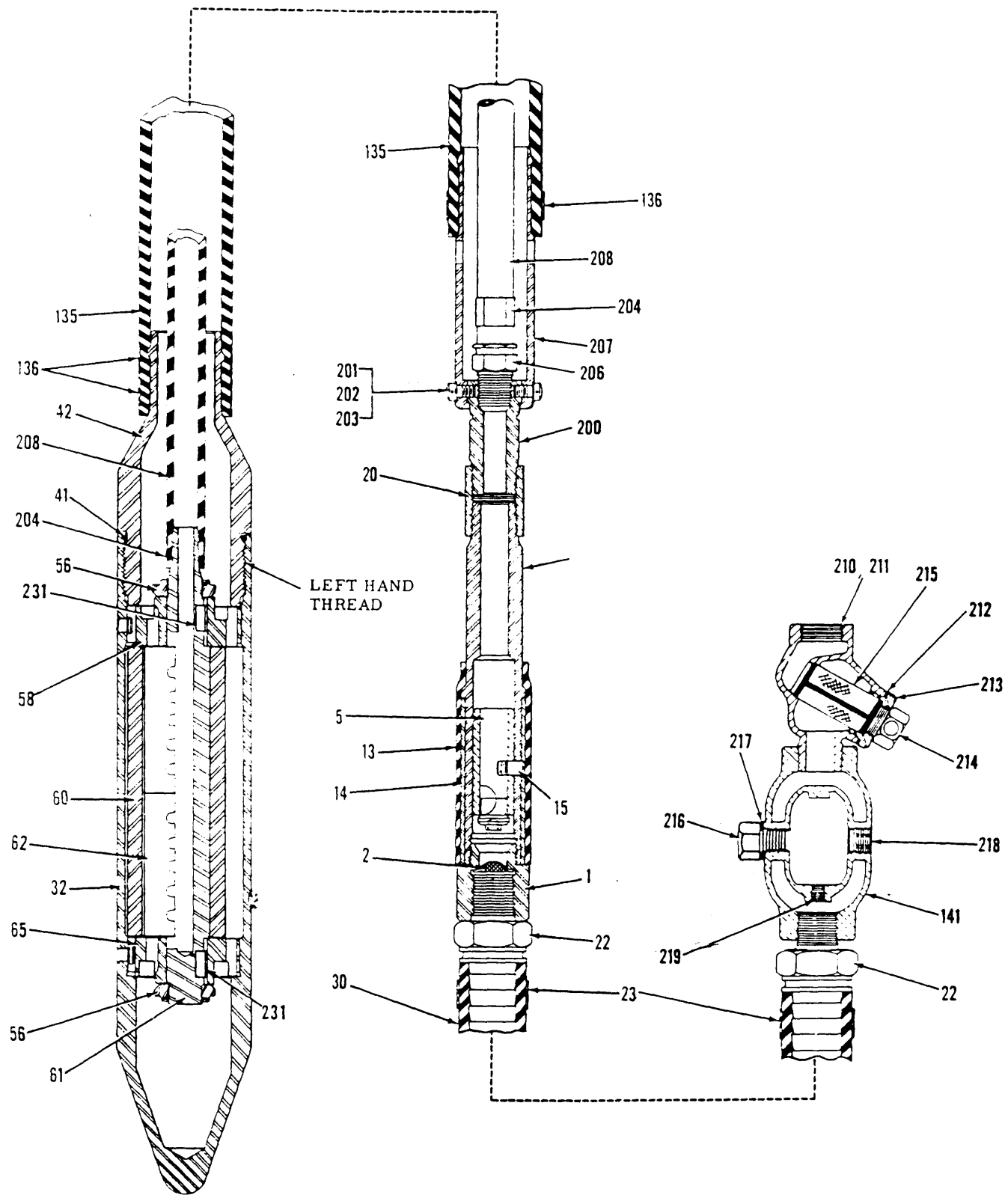

All Threads Are Right Hand Unless Otherwise Specified.

| Index No. | CP Part No. | Description   | No. Req'd. |
|-----------|-------------|---|------------|
| 1         | C-060374    | Cap-Handle  | 1          |
| 2         | C-037292    | Strainer-Air  | 1          |
| 5         | C-011060    | Plug-Handle   | 1          |
| 13        | C-075140    | Cover-Throttle Handle   | 1          |
| 14        | C-011061    | Sleeve-Handle   | 1          |
| 15        | C-011062    | Screw-Handle (Special)  | 1          |
| 19        | C-060448    | Live Air Handle Complete<br>(Incl: C-012050 and Index<br>No's. 1, 2, 13, 14 & 15) | 1          |
|           | C-012050    | Handle-Live Air<br>(Incl: #5)   | 1          |
| 20        | C-015026    | Coupling-Pipe (3/4")  | 1          |
| 22        | C-060315    | Nipple-Hose   | 2          |
| 23        | C-090675    | Clamp-Hose  | 2          |
| 30        | C-060445    | Hose-Intake (1")  | 1          |
| 31        | P-003442    | Bushing-Reducing  | 2          |
| 32        | C-058981    | Shell-Eccentric   | 1          |
| 41        | P-083094    | "O" Ring (-230)   | 1          |
| 42        | C-058978    | Cap-End   | 1          |
| 56        | C-058974    | Locknut-Bearing   | 2          |
| 58        | C-058975    | Plate-Upper End   | 1          |
| 60        | C-058979    | Weight-Eccentric  | 1          |
| 61        | C-058977    | Shaft-Eccentric (Incl: #229)  | 1          |
| 62        | C-058980    | Blade   | 2          |
| 65        | C-058976    | Plate-Lower End   | 1          |
| 135       | C-069151    | Hose-Exhaust  | 1          |
| 136       | C-090677    | Clamp-Hose  | 3          |
| 200       | C-038683    | Nipple-Exhaust Sleeve   | 1          |
| 201       | C-062118    | Screw (#14-24 x 7/16")  | 4          |
| 202       | C-012058    | Lockwasher (1/4")   | 4          |
| 203       | C-039438    | Lockwire  | 1          |
| 204       | C-090672    | Clamp-Hose  | 2          |
| 206       | P-002079    | Nipple-Hose   | 1          |
| 207       | C-039584    | Collar-Exhaust Swivel   | 1          |
| 208       | C-069153    | Hose-Live Air   | 1          |
| 210       | C-061460    | Line Air Strainer Complete<br>(Incl: #211 thru #215)                              | 1          |
| 211       | C-061339    | Housing-Air Strainer  | 1          |
| 212       | C-062965    | Gasket  | 1          |
| 213       | C-061341    | Gland-Air Strainer  | 1          |
| 214       | P-002293    | Gland Plug-Air Strainer   | 1          |
| 215       | C-061340    | Screen-Air Strainer   | 1          |
| 141       | C-015137    | Oiler (Incl: Index No's. 216<br>thru 219)   | 1          |
| 216       | C-015155    | Plug-Oiler Body   | 1          |
| 217       | C-015156    | Washer-Plug   | 1          |
| 218       | C-077941    | Plug-Pipe (3/8")  | 1          |
| 219       | C-068799    | Plug-Pipe (1/4")  | 1          |
| 231       | C-039980    | Key   | 2          |

## GENERAL INSTRUCTIONS

### Air Supply

For satisfactory performance, 90 psi of clean, dry air is required AT THE VIBRATOR with vibrator operating. Supply hose between tool and compressor should be 1" hose size or larger, used with couplings of a minimum 7/8" I.D. Small, portable compressors without aftercoolers should be blown down frequently in hot, humid weather.

### Operating Cautions

DO NOT USE VIBRATOR TO VIBRATE CONCRETE BUCKETS OR SIMILAR STEEL WHERE THERE IS SOLID METAL TO METAL CONTACT. DO NOT USE TO OPEN GATES OF CONCRETE BUCKETS.

### Preparing for Operation

Daily, before connecting vibrator to air hose, blow down air line to clear it of accumulated dirt and moisture. Pour about one ounce of recommended oil into air inlet and operate to allow oil to reach interior of tool.

### Lubrication

Daily, before using and after each eight hours service, pour about one ounce of recommended oil into air inlet and operate tool to allow oil to reach moving parts. The eight ounce line oiler (220) should be installed in the air line between air strainer (210) and intake hose (30) and regularly inspected and filled to provide constant and adequate lubrication to the vibrator.

### Oiler Adjustment

To adjust the oiler, remove oiler cap and turn knurled oil metering valve pin clockwise to closed position as shown by arrow on head of pin. Next turn pin counter-clockwise until valve is opened to provide required oil flow.

1. In hot weather, open about 1/2 turn.
2. For normal operation, open about one turn.
3. In very cold weather, open up to two turns.

### Recommended Lubricants

CHICAGO PNEUMATIC Airoilene Oil which contains moisture absorbent, rust inhibiting additives and will not separate while the tool is idle, is recommended for use with this tool and may be purchased under the following symbols:

1 gal. can - - - - - P-089507  
5 gal. can - - - - - P-089508

If recommended oil is not available, use a turbine or spindle grade oil with a viscosity of 100-150 SUS at 100°F which contains a rust inhibitor.

### Loss of Power/Erratic Action

Motor failure, loss of power or erratic action may be caused by factors outside the tool. Make the following checks.

1. Check air pressure. For rated performance, 90 psi air pressure is required AT THE TOOL with tool operating. A drop in air pressure may be

caused by lowered compressor output, excessive drain on the air line or by the use of hose or connections of improper size or in poor condition.

2. Check for wet or dirty air. Wet air tends to wash lubricant away from moving parts and to rust and corrode the interior of the tool. Dirt and foreign matter in the air supply will impede action of blades and eccentric weight and cause damage to the tool.

If above are in order:

1. Check air strainer (210); thoroughly clean and inspect screen (215). Replace if broken or distorted.
2. Check lubrication. Pour a liberal quantity of recommended oil cut with an equal amount of kerosene into inlet hose and operate vibrator slowly to flush out gum and foreign matter. Bump nose of vibrator on a block of wood to start, if necessary.
3. Disassemble tool and check blades (62); replace if worn or distorted.

### Disassembly/Assembly Cautions

To disassemble vibrator, first remove lock wire (203) and four screws (201) from swivel collar (207). Next clamp shell (32) carefully in a chain vise, holding shell close to the end cap (42) to avoid distorting thinner portion of shell wall. Remove end cap from shell--LEFT HAND THREAD! Use C-101824 bumping block and jar assembled shaft and weight (60) from shell. Remove lock nuts (56) and press eccentric shaft (61) out of end plates (58, 65). Remove weight and blades (62).

Thoroughly clean and inspect eccentric assembly. Be sure old blades or replacement blades are a free, sliding fit in slot of eccentric shaft. If blade sticks, check slot for burrs.

When assembling Vibrator, apply a few drops of a good grade adhesive such as American Sealant Co's. Loctite Retaining Compound or equivalent to the end plates (58, 65), press upper end plate with key (231) on eccentric shaft. Apply a few drops of Loctite "A" or an equivalent adhesive to locknuts (56) and screw locknut against upper end plate (58) snug plus 1/8 turn. Making sure no sealant can get on blades (62), assemble them in shaft with slanted face toward exhaust porting as shown in Fig. 1.

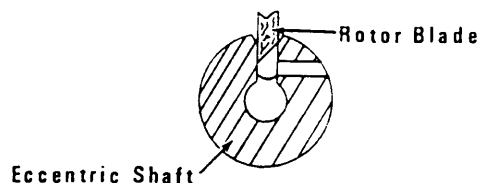

Fig. 1

Place eccentric weight (60) on shaft, press lower end plate (65) on shaft and key and tighten locknut as described above. Make sure weight moves easily between end plates, allowing .004"-.007" clearance.

**CAUTION:** Check part numbers of end plates. C-058975 upper end plate and C-058976 lower end plate and be sure they are correctly assembled. Eccentric assembly will not enter shell if they are reversed.

Heat shell (32) moderately to expand the bore and drive eccentric assembly into shell until it bottoms firmly. Note that flat part of end plates must be carefully aligned with flats in interior of shell.

Pull live air hose (208) through end cap (42) and clamp to end of eccentric shaft. Holding shell in a chain vise, screw end cap into shell as tightly as possible--LEFT HAND THREAD

After assembling end cap, if a new exhaust hose is required, force hose on cap. Leave at least 3/4" of hose for lower hose clamp (136) and assemble upper clamp first. As upper clamp is tightened, hose flows downward, leaving additional space for lower clamp.

Fasten swivel collar (207) to inlet using four screws (201) and lock wire (203).

## Daily Lubrication, Operation, And Maintenance Instructions

### Important

CP-3250 Concrete Vibrators are constructed of precision built parts designed to operate at close clearances and in perfect alignment. Use reasonable care in disassembly and assembly and observe the following instructions to maintain the tool for many hours of trouble free service.

### Air Supply And Lubrication

Follow the instructions on Page 4 under "Preparing For Operation" and "Lubrication" before operating Vibrator. It is important to blow down and clear the air line to avoid getting dirt and water into the motor and it is very important to lubricate the Vibrator ADEQUATELY with the RIGHT KIND of oil. Some SAE #5 Non-Detergent oils meet the requirements listed under "Recommended Lubricants" and are recommended. Specific recommended oils include

Shell Tellus #23. Non Fluid Oil Corp's.  
#88 NR and Mobil Oil Co's. Almo #1.

### Operation

1. Check air pressure, 90 psi of clean, dry air is required AT THE TOOL for rated performance.
2. Check oil flow by holding your hand in front of exhaust holes. If there is enough oil in the air line, you will feel oil on your hand.
3. Do not submerge the vibrator exhaust in concrete nor allow concrete, water or foreign material to enter exhaust of Vibrators of flexible exhaust hose type.
4. NEVER use Vibrator to vibrate concrete buckets where there is solid metal to metal contact.
5. Check oiler frequently. Under average conditions it will require refilling twice in eight hours.
6. If Vibrator does not start when air is turned on, start tool by jarring the nose of the Vibrator on ground to alter blade position and enable tool to start. DO NOT risk damage to the shell by striking it with a hammer or other object.

### Cleaning, Flushing & Storage

1. Daily after use, remove Vibrator to a clean-up area where compressed air is available.
2. Clean concrete, excess oil and dirt off exterior of Vibrator. DO NOT submerge exhaust in water when cleaning.
3. CHECK STRAINERS (2, 215) AND CLEAN IF NECESSARY.
4. Pour about eight ounces of diesel fuel, kerosene or commercial solvent into air inlet of Vibrator. Attach air supply and operate tool until flushing solvent is exhausted.
5. Refill oiler and check adjustment.
6. Visually check external parts, including weld on nose. Reweld by arc welding if cracked. DO NOT gas weld and risk warping shell.
7. Store Vibrator by hanging on a rack with exhaust holes facing down to drain any moisture or condensation away from motor.

Eccentric Assembly  
Bumping Block C-101824

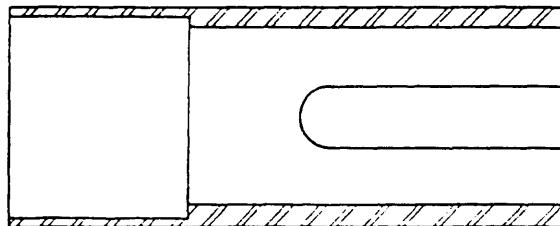

Locknut- Socket  
C-110739

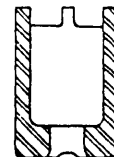

## SPARE PARTS SERVICE CHART

Order Spare Parts based on number of tools in use.

EXAMPLE: For 10 tools in use: stock 10 high wear items, 7 medium wear items, 7 medium wear items, etc.

This service chart is based on average tool usage. The service life of parts may vary in specific cases depending on usage.

### LEGEND

- X—Type of wear, if no other comments apply.
- D—Easily damaged during disassembly and assembly.
- R—Require replacement at recommended intervals.
- R1—Replace each time tool is disassembled.
- R2—Replace each second time tool is disassembled.

| Index No. | CP Part No. | Description                  | No. Req'd. | High Wear 100% | Medium Wear 70% | Low Wear 30% | Non Wear 10% | Subject To External Damage |
|-----------|-------------|------------------------------|------------|----------------|-----------------|--------------|--------------|----------------------------|
| 1         | C-060374    | Cap-Handle                   | 1          |                |                 |              | X            |                            |
| 2         | C-037292    | Strainer-Air                 | 1          |                | X               |              |              |                            |
| 5         | C-011060    | Plug-Handle                  | 1          |                |                 | X            |              |                            |
| 13        | C-075140    | Cover-Throttle Handle        | 1          | X              |                 |              |              |                            |
| 14        | C-011061    | Sleeve-Handle                | 1          |                |                 | X            |              |                            |
| 15        | C-011062    | Screw-Handle                 | 1          |                | X               |              |              |                            |
| 19        | C-012050    | Handle-Live Air              | 1          |                |                 |              |              | X                          |
| 20        | C-015026    | Coupling-Pipe                | 1          |                |                 |              |              | X                          |
| 22        | C-060315    | Nipple-Hose                  | 2          |                |                 |              |              | X                          |
| 23        | C-090675    | Clamp-Hose                   | 2          | R1             |                 |              |              |                            |
| 30        | C-060445    | Hose-Intake                  | 1          |                |                 |              |              | X                          |
| 31        | P-003442    | Bushing-Reducing             | 2          |                |                 |              |              | X                          |
| 32        | C-058981    | Shell-Eccentric              | 1          |                | X               |              |              |                            |
| 41        | P-083094    | "O" Ring                     | 1          | R1             |                 |              |              |                            |
| 42        | C-058978    | Cap-End                      | 1          |                |                 | X            |              |                            |
| 56        | C-058974    | Locknut-Bearing              | 2          | R2             |                 |              |              |                            |
| 58        | C-058975    | Plate-Upper End              | 1          |                | X               |              |              |                            |
|           | C-058984    | Button-Liner Key             |            |                |                 |              |              |                            |
| 60        | C-058979    | Weight-Eccentric             | 1          |                |                 | X            |              |                            |
| 61        | C-058977    | Shaft-Eccentric (Incl: #229) | 1          |                |                 | X            |              |                            |
| 62        | C-058980    | Blade                        | 2          | X              |                 |              |              |                            |
| 65        | C-058976    | Plate-Lower End              | 1          |                | X               |              |              |                            |
| 135       | C-069151    | Hose-Exhaust                 | 1          |                |                 |              |              | X                          |
| 136       | C-090677    | Clamp-Hose                   | 3          | R1             |                 |              |              |                            |
| 200       | C-038683    | Nipple-Exhaust Sleeve        | 1          |                |                 |              |              | X                          |
| 201       | C-062118    | Screw                        | 4          | D              |                 |              |              |                            |
| 202       | C-012058    | Lockwasher                   | 4          | D              |                 |              |              |                            |
| 203       | C-039438    | Lockwire                     | 1          | R1             |                 |              |              |                            |
| 204       | C-090672    | Clamp-Hose                   | 2          | R1             |                 |              |              |                            |
| 206       | P-002079    | Nipple-Hose                  | 1          |                |                 | X            |              |                            |
| 207       | C-039584    | Collar-Exhaust Swivel        | 1          |                |                 |              |              | X                          |
| 208       | C-069153    | Hose-Live Air                | 1          |                |                 | X            |              |                            |
| 211       | C-061339    | Housing-Air Strainer         | 1          |                |                 |              |              | X                          |
| 212       | C-062965    | Gasket                       | 1          |                | X               |              |              |                            |
| 213       | C-061341    | Gland-Air Strainer           | 1          |                |                 | D            |              |                            |
| 214       | P-002293    | Gland-Plug-Air Strainer      | 1          |                |                 |              |              | D                          |
| 215       | C-061340    | Screen-Air Strainer          | 1          |                |                 | D            |              |                            |